

# Operating Instructions

## 3/8" Reversible Air Drill



**BT-401**



Industrial Air Products

**Beaver Tools, Inc.**  
4031 Gravois Avenue  
St. Louis, MO 63116

**800-365-6677**

314-773-5999

Fax: 314-773-8490

Email: [tooltalk@beavertools.com](mailto:tooltalk@beavertools.com)

[www.beavertools.com](http://www.beavertools.com)



Industrial Air Products

**800-365-6677**

[www.beavertools.com](http://www.beavertools.com)

# ***Thank You!***

---

Thank you for purchasing a quality industrial air product from Beaver Tools.

Read all these operating instructions before attempting to operate this product. Keep the operating instructions with this product or in a safe place accessible to all users.

<b>Safety First</b>	<b>3</b>
<b>Tool Maintenance</b>	<b>4</b>
<b>Operating Instructions</b>	<b>5</b>
<b>Accessories</b>	<b>5</b>
<b>Parts Diagram</b>	<b>6</b>
<b>Warranty Package</b>	<b>7</b>

# ***Warranty Package***

---

All industrial air products come with the Beaver Tools warranty package. The warranty package ensures that you purchased a professional power tool that is built to last.

If you have any questions about the warranty, contact a customer service representative at 800-365-6677.

**1**

## **Year Warranty**

We will repair or replace any part or parts of the product or accessory that proves to be defective in workmanship or material. Beaver Tools warrants products for a period of one year from the date of original purchase.

**1**

## **Year Service**

Beaver Tools will maintain any of our products and replace worn parts for free, anytime during the first year after purchase.

### **LIMITED ONE YEAR WARRANTY**

Beaver Tools, Inc. warrants its professional power tools for a period of one year from the date of original purchase. We will repair or replace at our option, any part or parts of the product and accessories covered under this warranty which, after examination, proves to be defective in workmanship or material during the warranty period. For repair or replacement return the complete tool or accessory, transportation prepaid, to Beaver Tools. Proof of purchase may be required. This warranty does not apply to repair or replacement required due to misuse, abuse, normal wear and tear or repairs attempted or made by other than our service center.

Any implied warranty, including the implied warranties of merchantability and fitness for a particular purpose, will last only for one year from the date of purchase.

The foregoing obligation is Beaver Tools' sole liability under this or any implied warranty and under no circumstances shall Beaver Tools be liable for any incidental or consequential damages. Some states do not allow limitation on how long an implied warranty lasts or the exclusion or limitation of incidental or consequential damages, so the above limitation or exclusion may not apply to you.

This warranty gives you specific legal rights and you may also have other legal rights which may vary from state to state.

# Parts Diagram

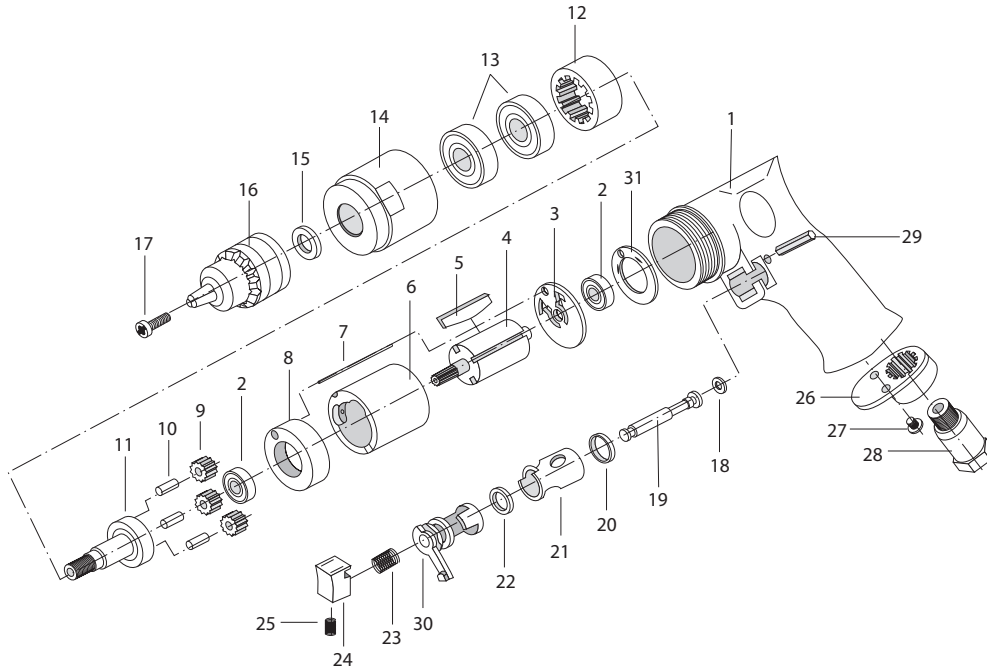

Ref. No.	Description	Part No.	Ref. No.	Description	Part No.
1	Housing	BP-401-01	17	Chuck Screw	BP-401-17
2	Rear Bearing	BP-401-02	18	O-ring	BP-401-18
3	End Plate	BP-401-03	19	Valve Stem	BP-401-19
4	Rotor	BP-401-04	20	O-ring	BP-401-20
5	Rotor Blade	BP-401-05	21	Reverse Bushing	BP-401-21
6	Cylinder	BP-401-06	22	O-ring	BP-401-22
7	Pin	BP-401-07	23	Trigger Spring	BP-401-23
8	Front Plate	BP-401-08	24	Trigger	BP-401-24
9	Gear	BP-401-09	25	Trigger Screw	BP-401-25
10	Pin	BP-401-10	26	Exhaust Diffuser	BP-401-26
11	Work Spindle (3/8")	BP-401-11	27	Screw	BP-401-27
12	Thread Ring Gear	BP-401-12	28	Air Inlet	BP-401-28
13	Ball Bearing	BP-401-13	29	Spring Pin	BP-401-29
14	Clamp Nut (3/8")	BP-401-14	30	Reverse Lever	BP-401-30
15	Nut	BP-401-15	31	Rear Gasket	BP-401-31
16	Chuck (3/8")	BP-401-16			

# Safety First

At Beaver Tools, your safety is our concern. Following are some simple guidelines that will keep you safe when operating your Beaver Tools product.

## Protect Yourself

- Safety Glasses**  
Wear safety glasses while operating power tools to avoid needless eye injuries.
- Dust Mask**  
If the operation creates dust, wear a face or dust mask.
- Ear Protection**  
To safeguard against possible hearing loss, it is recommended to wear ear plugs when exposed to high decibels for extended time periods.
- Dress Properly**  
Do not wear loose clothing or jewelry. Loose clothing, draw strings and jewelry can be caught in moving parts. Rubber gloves and non-skid footwear are recommended when working outdoors. Wear protective hair covering to contain long hair.
- Stay Alert**  
Watch what you are doing at all times and use common sense. Do not operate power tools when you are tired or while under the influence of medication or alcohol.

## Maintain a Safe Work Environment

- Keep Work Area Clean**  
Cluttered areas and benches invite injuries. Beaver Tools recommends using drop down air lines to keep work areas and floors free from air hoses. Beaver offers two different retractable air hose styles and sizes (BA-1207, BA-1208, BA-1215 and BA-1216).
- Avoid Dangerous Environments**  
Don't expose power tools to rain. Don't use power tools in wet or damp locations. Keep area well lit. Avoid chemical or corrosive environment. Do not use tool in the presence of flammable liquids or gases.
- Keep Children Away**  
Do not let anyone but the operator come into contact with the tool or air hose. All children should be kept away from work area.
- Store Idle Tools**  
When not in use, tools should be stored in a dry, high or locked up place and out of reach of children.
- Avoid Unintentional Starting**  
Do not carry an air connected tool with finger on trigger switch. Be sure nothing is depressing trigger when connecting tool to air hose. Keep hands, body and clothes clear of blades, bits, cutters, etc. when connecting the tool. Always disconnect tool from air supply before: handing the tool to another person, leaving the work area, moving the tool to another location, or performing tool maintenance.

# Tool Maintenance

Tool maintenance is an important part in keeping your Beaver Tools in proper working condition.

## 1. Lubrication

Always lubricate your pneumatic tools. Use one drop daily or several drops weekly of ten weight non-detergent air tool oil. We recommend our Beaver Tools Pneumatic Lubricant (BA-PL1). It comes in a bottle with a flip-top spout for easy pouring. If the Beaver Tool is not lubricated, the warranty is voided.

## 2. Keep Moisture Out

Keep moisture out of your Beaver Tools. We recommend our Mini Water Separator (BA-113) or our Air Control Unit (BA-421). These units will help keep moisture from accumulating inside your air tools. Allowing moisture to collect in you Beaver Tool will void the warranty.

## 2. Clean Tools

Keep tools clean for better and safer performance. Always keep handles dry, clean and free from oil and grease.

## 3. Air Pressure

Always maintain the appropriate air pressure. Beaver Tools run on a minimum of 90 PSI and a maximum of 110 PSI. We recommend our Air Regulator with Gauge (BA-111) to monitor your air pressure at all times.

## 4. Air Hose

Check your air hose for leaks or cracks. Vinyl hoses do not kink or crack like plastic hoses.

Beaver Tools carries a line of vinyl air hoses that are either coiled or retractable.

## 5. Stay Sharp

Check all blades, bits, cutters, etc. for sharpness. It is important to keep tools sharp for optimum performance.

## 6. Check for Damaged Parts

Before further use of a tool, a guard or other part that is damaged should be carefully checked to determine that it will operate properly and perform its intended function. Check for alignment of moving parts, binding of moving parts, breakage of parts, mounting, and any other conditions that may affect its operation. Beaver Tools recommends that only identical replacement parts be used for repairs.



# Instructions & Accessories

## 3/8" Reversible Drill Operation

1. Always disconnect the drill from the air hose before changing bits and making adjustments. Air pressure should be a minimum of 90 PSI to a maximum of 110 PSI.



2. Always be sure the bit is securely in place to prevent it from slipping during use.
3. Make certain that the workpiece is rigidly held in desired position and free of obstructions.
4. When first using the 3/8" reversible drill, it is a good idea to test it out on sample material. This will allow you to get a feel and recognize the sound of the motor when it is operating at its most efficient load.
5. To use the drill, squeeze the trigger. Hold the drill firmly against the work. Keep pressure constant. To reverse, simply slide the lever down. This lever is conveniently located near the trigger and can easily be accessed by your thumb.

### Specifications

- 1800 RPM Free Speed
- 3/8" Reversible
- Average 7 CFM
- Weight: 2.5 pounds
- Size 7" length

## Accessories

Swivel Connector	BA-381	Pneumatic Tool Oil	BA-PL1
Coiled Air Hose		Automatic Oiler	BA-115
1/4" x 30'	BA-1202	Mini Water Separator	BA-113
3/8" x 30'	BA-1203		